

SCAFFALATURE
DI DIPOSITO E STOCCAGGIO
SHELVING
FOR DEPOSIT AND STORAGE







RICERCA, INNOVAZIONE E PERSONALIZZAZIONE RESEARCH, INNOVATION AND CUSTOMIZATION



Nel nostro ufficio R&D di Travagliato lavora uno staff dalla filosofia progettuale ben precisa, che punta a ristabilire l'equilibrio tra design, concetto e funzionalità.

Nel reparto produttivo, acciaio ed alluminio sono forgiati da personale altamente specializzato con processi di lavorazione di grande precisione, che rappresentano da 50 anni questa realtà produttiva.

The staff of our R&D department in Travagliato work according to a strictly-defined design philosophy aimed at restoring the balance between design, concept and functionality.

In our manufacturing plant highly skilled workers forge steel and aluminum using ultra-precise processes that have been the company trademark for 50 years.

In unserer R&D Abteilung in Travagliato arbeitet ein Team mit einer genauen Planungsphilosophie, mit dem Ziel das Gleichgewicht zwischen Design, Konzept und Funktionalität wiederherzustellen.

In unserer Produktionsabteilung werden Stahl und Aluminium von hoch qualifiziertem Personal zusammen mit den feinsten Arbeitsprozessen geschmiedet, die seit 50 Jahren diese Fertigungs-wirklichkeit darstellen.

L'équipe qui forme notre service de recherche et développement de Travagliato adopte une approche visant à établir un équilibre entre design, concept et fonctionnalités.

Dans nos ateliers, l'acier et l'aluminium sont forgés par des spécialistes utilisant des technologies de pointe qui ont fait de cette production une réalité depuis 50 ans.

En nuestro departamento de R&D de Travagliato trabaja una plantilla con una filosofía de proyecto muy precisa, la cual persigue restablecer el equilibrio entre diseño, concepto y funcionalidad.



















En la sección de producción, personal altamente especializado forja acero y aluminio mediante procesos de elaboración de gran precisión los cuales representan esta realidad productiva desde hace 50 años.













LEGENDA
LEGEND























STRUCTURAL DETAILS

 <p>AISI 304 Struttura in acciaio inox Stainless steel structure</p>	 <p>Al Struttura in alluminio Aluminum structure</p>	 <p>Zn Struttura in acciaio zincato Galvanized steel structure</p>	 <p>PP Struttura in polipropilene Polypropylene structure</p>
 <p>AISI 304 Chassis in acciaio inox Stainless steel chassis</p>	 <p>AL Chassis in alluminio Aluminum chassis</p>	 <p>ZN Chassis in acciaio zincato Galvanized steel chassis</p>	 <p>Ruote pneumatiche Pneumatic wheels</p>
 <p>Ruote girevoli Swivel wheels</p>	 <p>Ruote girevoli con freno Swivel wheels with brake</p>	 <p>Ruote fisse Fixed wheels</p>	 <p>Struttura ripiegabile Folding structure</p>
 <p>Nervatura di rinforzo Reinforcement ribs</p>	 <p>Legno massello e moquette Solid wood and fitted carpet</p>	 <p>Truciolare nobilitato laminato Laminated particleboard body</p>	
 <p>Base in plastica contenitiva Plastic base containing plate</p>	 <p>Reggisacco in gomma iniettata Injected rubber bagholder</p>	 <p>Reggisacco apribile in gomma iniettata Injected rubber openable bagholder</p>	

SAFETY DETAILS

 <p>Paracolpi circolari Circular rubber buffer</p>	 <p>Paraurti in PVC PVC bumper</p>	 <p>Paraurti in PEHD HDPE bumper</p>	 <p>Paracolpi angolari Corner buffer</p>
 <p>Sanificabile Sanitizable</p>	 <p>Lavabile a basse temperature Low temperatures washable</p>	 <p>Lavabile ad alte temperature High temperatures washable</p>	
 <p>Chiusura non rumorosa Silent closing</p>	 <p>A tenuta d'aria Air-tight</p>	 <p>Senza giunzioni e depositi di sporco Without joins and dirt deposit</p>	

TECHNICAL DETAILS

 <p>Ripiani ribaltabili Folding shelves</p>	 <p>Ripiani estraibili Removable shelves</p>	 <p>Ripiani reversibili Reversible shelves</p>	 <p>Ripiani regolabili in altezza Height adjustable shelves</p>
 <p>Fornibili smontati Supplied for assembling</p>	 <p>Saldatura a TIG TIG welding</p>	 <p>An Alluminio anodizzato Anodized finish</p>	 <p>EI Acciaio inox elettrolucidato Electropolished stainless steel</p>
 <p>Rack interno con guide Interior rack with slides</p>	 <p>Rack interno asportabile Removable interior rack</p>	 <p>Accatastabili Stackable</p>	 <p>Impilabili Overlappable</p>
 <p>Sportello ribaltabile Tilting door</p>	 <p>Porte apribili a 270° 270° door opening</p>	 <p>Magnete di bloccaggio Clamping magnet</p>	 <p>Chiusura doppio bloccaggio Double locking closure</p>
 <p>Elevazione manuale Manual lifting</p>	 <p>Elevazione automatica Automatic lifting</p>	 <p>Seduta ergonomica Ergonomic seating</p>	
 <p>Maniglie incassate Built-in handles</p>	 <p>Maniglie con molla a caduta Spring fold down handles</p>		



SCAFFALATURE
DI DEPOSITO E STOCCAGGIO

SHELVING
FOR DEPOSIT AND STORAGE





IN ACCIAIO
INOX

*IN STAINLESS
STEEL*

PAGE **52**



IN LEGA LEGGERA

IN LIGHT ALLOY

PAGE **60**

SCAFFALATURE DI DEPOSITO E STOCCAGGIO

SHELVING FOR DEPOSIT AND STORAGE

IN ACCIAIO INOX
IN STAINLESS STEEL



AISI
INOX
304



Struttura realizzata interamente in acciaio inox AISI 304 (1.4301) completamente saldata con procedimento TIG su tutti i punti di giunzione a garanzia di una perfetta igiene.

Il posizionamento dei ripiani e/o delle guide avviene in modo veloce e semplice senza l'ausilio di chiavi e/o utensili o del parziale smontaggio della struttura stessa.

Finitura superficiale di elettrolucidatura a lavorazione ultimata.

Structure entirely made of stainless steel AISI 304 completely welded on all junction points with TIG process in order to guarantee perfect hygiene.

The positioning of the shelves and/or of the guides is quick and easy. No need of tools, wrenches or structure disassemble.

Upon structure is completed, the surface is finished with an electro polish process.



CROCIERA - CROSS BRACE

Indispensabile per rendere la scaffalatura più stabile.
Cross brace structure improves structure stability.

Adatti allo stoccaggio di contenitori di sterilizzazione e/o cesti di contenimento di set sterili e materiale vario di confezionamento.

Suitable for the storage of sterilization containers, baskets for sterile sets and miscellaneous packaging materials.



GUIDA TELESCOPICA TELESCOPIC GUIDES

Consente l'estrazione totale del ripiano/cesto. Funzionale al facile posizionamento e prelievo di materiale.

Suitable for easy placement and retrieval of material from baskets and/or shelves.

SCAFFALATURA IN ACCIAIO INOX SHELVING IN STAINLESS STEEL

Scaffalatura fissa
Fixed shelving

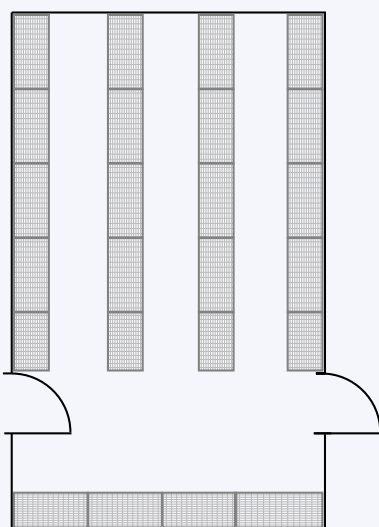

Scaffalatura mobile
Mobile shelving

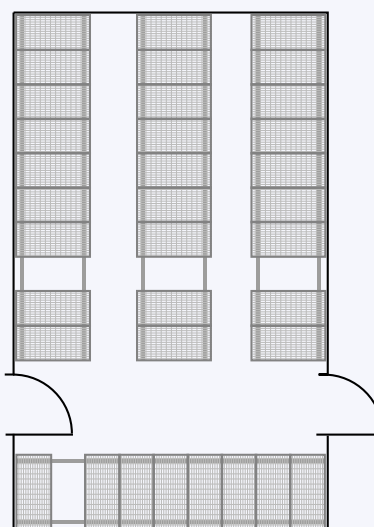

VANTAGGI SCAFFALATURA MOBILE - MOBILE SHELVING ADVANTAGES

La movimentazione manuale dei singoli moduli sulle basi di scorrimento permette di aprire un accesso per l'operatore alla corsia desiderata.

Ottimizzando così gli spazi inutilizzati, ne consegue un migliore utilizzo dello spazio destinato allo stoccaggio a favore di un incremento della capacità del magazzino

The movement of each individual modules on the sliding base allows the operator to open an access to the desired aisle.

By optimizing unused areas, the result is better utilization of storage space in favor of an increased storage capacity.

- Aumento delle capacità di stoccaggio almeno del **50%**
- Migliore organizzazione dello spazio
- Adatto a qualunque ambiente di lavoro

- Increase of storage capacity by **50%**
- Better space organization
- Suitable for any work environment



TOP-TRACK SYSTEM

Scaffalatura mobile con scorrimento superiore - *Mobile shelving with top sliding*

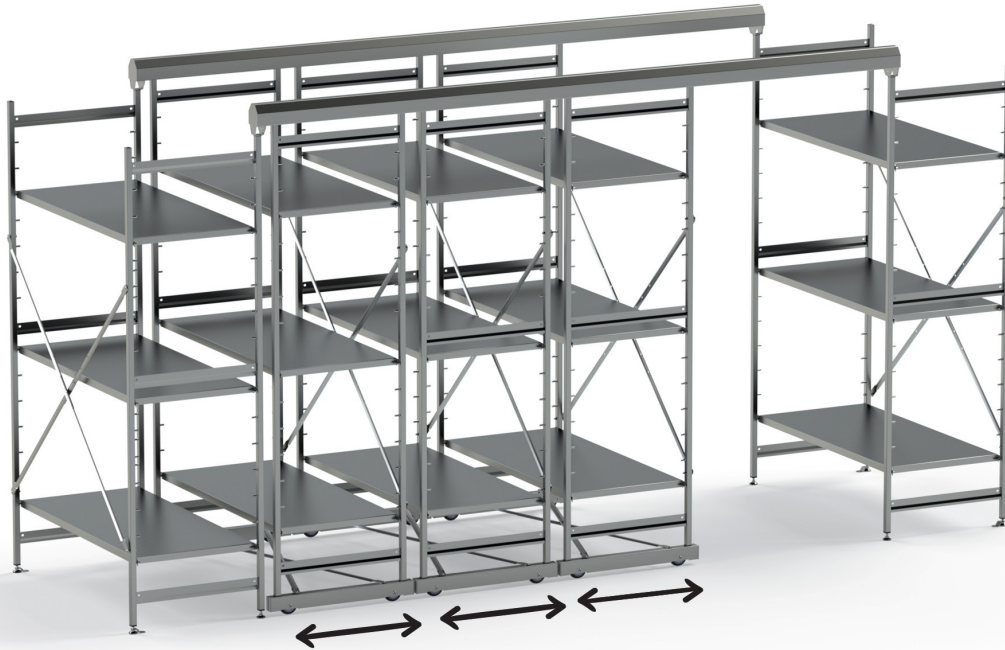

GROUND-TRACK SYSTEM

Scaffalatura mobile con scorrimento inferiore - *Mobile shelving with ground sliding*

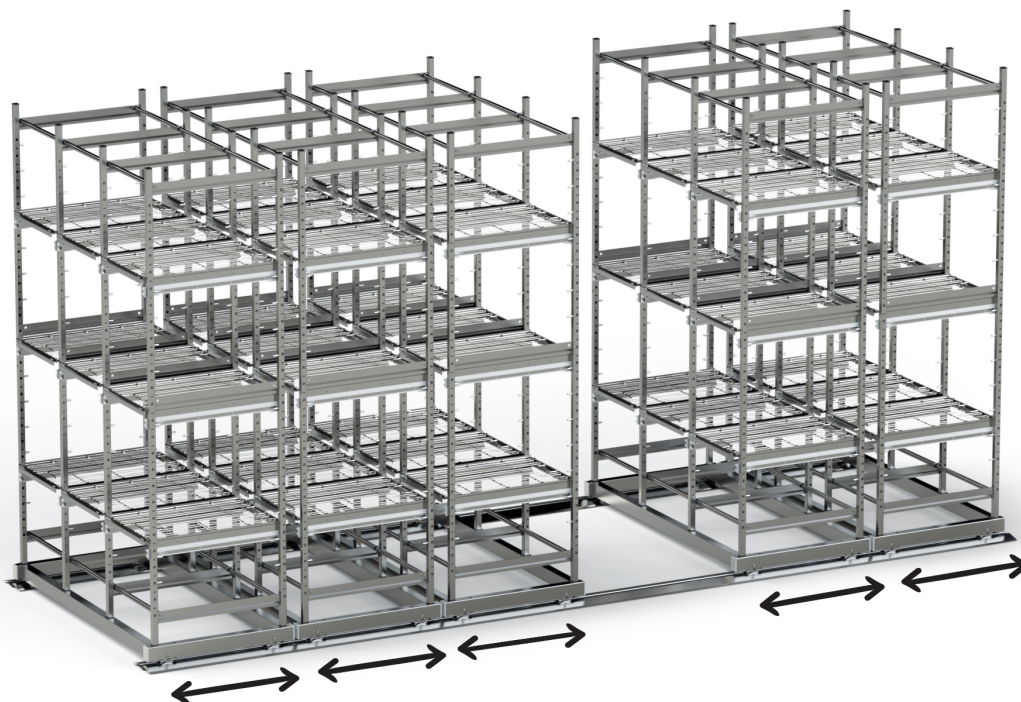

COMPONENTI **SCAFFALATURA FISSA** IN ACCIAIO INOX
 COMPONENTS FOR **FIXED SHELVING** IN STAINLESS STEEL

Spalla - Square section frame

AXUF

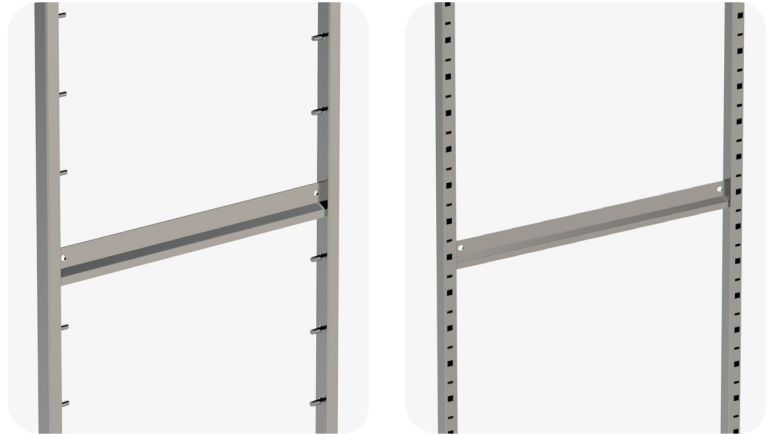
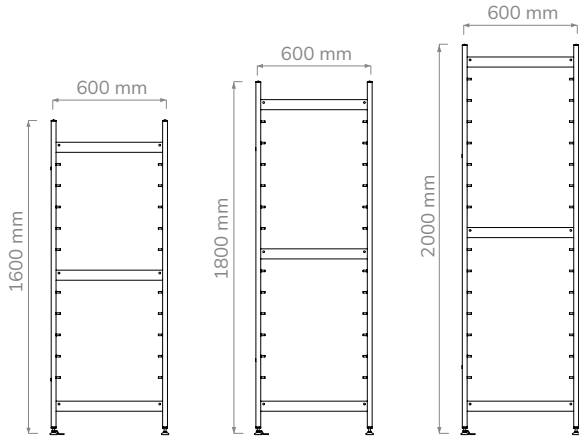

Distanziali - Spacer set

AXDIS

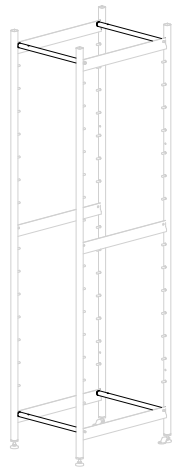

Lunghezza
Length

- DIN** 300 mm
- ISO** 400 mm
- G** 325 mm



Crociera - Cross brace

CBREG



**Piedino regolabile
Adjustable foot**

AXUF-SP





COMPONENTI SCAFFALATURA MOBILE IN ACCIAIO INOX COMPONENTS FOR MOBILE SHELVING IN STAINLESS STEEL

Elementi di scorrimento per TOP-TRACK system - Sliding elements for TOP-TRACK system

TPTK-REG



TPTK + TPTK-CAP



Elementi di scorrimento per GROUND-TRACK system - Sliding elements for GROUND-TRACK system

GRTK-REG



GRTK



Non ci sono limiti di lunghezza
No length limit

Struttura per colonne - Column square frame

(GROUND-TRACK and TOP TRACK system)

SUPSP

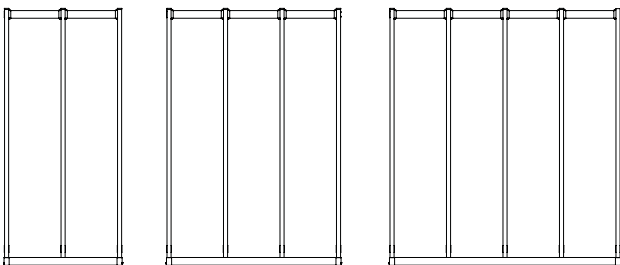

OPTIONAL SCAFFALATURE IN ACCIAIO INOX OPTIONAL SHELVING IN STAINLESS STEEL

Guide - Guides

ISO-RN

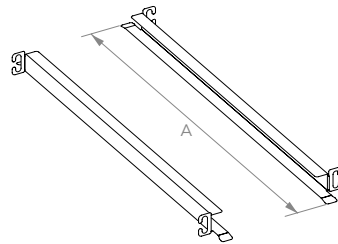

Coppia di guide per cesti ISO.
Pair of guides for ISO baskets.
Schienen für ISO-körbe.
Paire de rails pour paniers ISO.
Par de guías para cestas ISO.

(mm)	A
ISO-RN	600

DIN-RN

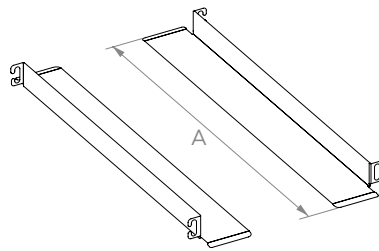
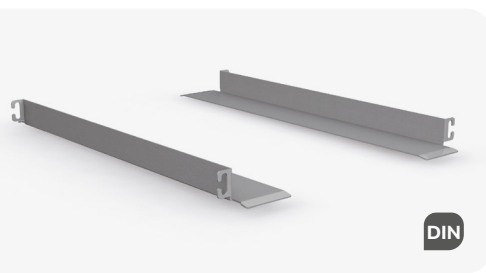

Coppia di guide per container DIN.
Pair of guides for DIN containers.
Schienen für DIN-behälter.
Paire de rails pour conteneur DIN.
Par de guías para contenedores DIN.

(mm)	A
DIN-RN	600

RNDIN-SH

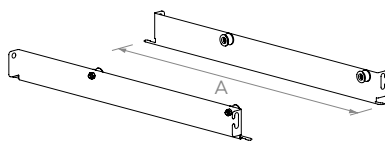

Coppia di guide per ripiano telescopico.
Pair of guides for telescopic shelf.
Schienenpaar für teleskopischen Regalboden.
Paire de rails pour rayon télescopique.
Par de guías para estantes telescópicos.

(mm)	A
RNDIN-SH	580

NY-RN60

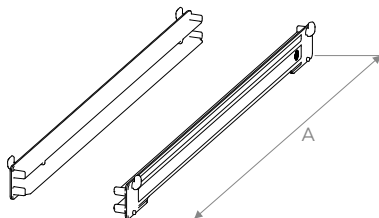

Coppia di guide in policarbonato.
Pair of polycarbonate guides.
Führungspaar aus Polycarbonat.
Paire de rails en polycarbonate.
Par de guías de policarbonato.

(mm)	A
NY-RN60	615

ISOTEL-RN

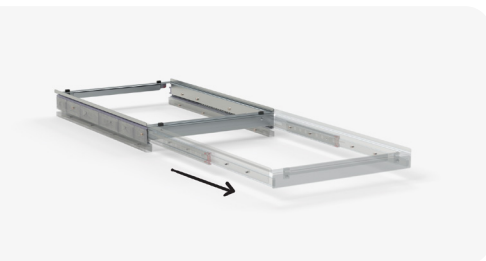

Struttura telescopica da agganciare alle guide NY-RN60 per ripiani e cesti.
Telescopic structure to attach on NY-RN60 guides. Suitable for easy access to shelf/basket content.
Teleskopstruktur zum Einhängen in NY-RN60 Führungen für Regale und Körbe.
Structure télescopique à accrocher aux glissières NY-RN60 pour étagères et paniers.
Estructura telescópica para enganchar a guías NY-RN60 para baldas y cestas.

Pannelli identificativi - Identification panels



Disponibili in diversi colori (colori a richiesta).
Different colours available.
Verschiedene Farben verfügbar.
Différentes couleurs disponibles.
Diferentes colores disponibles.

Ripiani e cesti - Shelves and baskets

LREG (lamiera piana-plate shelf) - WREG (grigliato-wire shelf)



ISO DIN

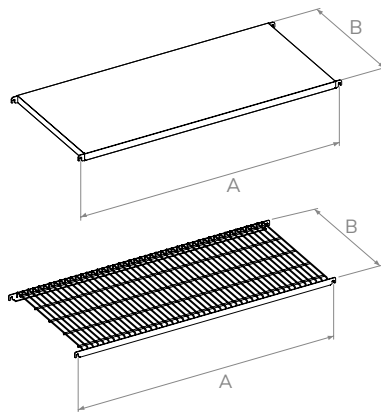

Ripiano in acciaio inox.
Stainless steel shelf.
Regalboden aus Blech aus rostfreiem Edelstahl.
Étagère en tôle en acier inoxydable.
Estante de chapa de acero inoxidable.

(mm)	A	B
LREG100	1000	540
LREG120	1200	540
LREG140	1400	540
WREG100	1000	540
WREG120	1200	540
WREG140	1400	540

SHDIN-RN (for RNDIN-SH)

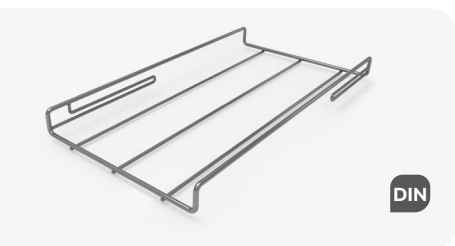

DIN

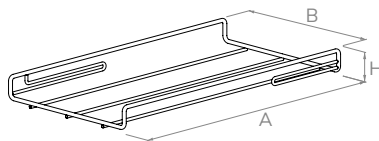

Ripiano telescopico per container DIN.
Telescopic shelf for DIN containers.
Teleskopischer Regalboden für DIN Behälter.
Rayon télescopique pour conteneur DIN.
Estante telescopico para contenedores DIN.

(mm)	A	B	H
SHDIN-RN	600	320	60

SHELF (for NY-RN)

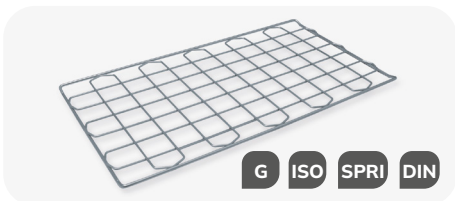

G ISO SPRI DIN

* Ripiano in filo inox.
** Stainless steel wire shelf.*
** Regalboden aus Draht aus rostfreiem Edelstahl.*
** Rayon en fil d'acier inoxydable.*
** Estante en alambre de acero inoxidable.*

BAC6040



ISO

* Contenitore ISO in policarbonato.
** ISO polycarbonate container.*
** ISO-Behälter aus Polykarbonat.*
** Conteneur ISO en polycarbonate.*
** Contenedor ISO de policarbonato.*

ISO6040 (for NY-RN)



SPRI ISO

* Cesto in filo inox.
** Stainless steel wire basket.*
** Korb aus Draht aus rostfreiem Edelstahl.*
** Panier en fil d'acier inoxydable.*
** Cesta de alambre de acero inoxidable.*

* Vedi pagina 48/49 per le misure complete. * See page 48/49 for complete dimension chart.

SCAFFALATURE DI DEPOSITO E STOCCAGGIO

SHELVING FOR DEPOSIT AND STORAGE

IN LEGA LEGGERA
IN LIGHT ALLOY

VERSATILITÀ - ADAPTABILITY

Il collegamento dei montanti verticali a mezzo dei set di distanziali, permette la configurazione di scaffalature di lunghezze diverse. Infinite soluzioni a seconda delle necessità.

The connection of uprights and spacers allows the configuration of countless shelving designs. Multiple solutions of different lengths and layouts.



SCAFFALATURA AD ANGOLO - CORNER SHELVING

Con l'aggiunta di un semplice elemento avrete la possibilità di creare una scaffalatura ad angolo.

Thanks to the addition of a single corner element, it is possible to make the most of all available space.



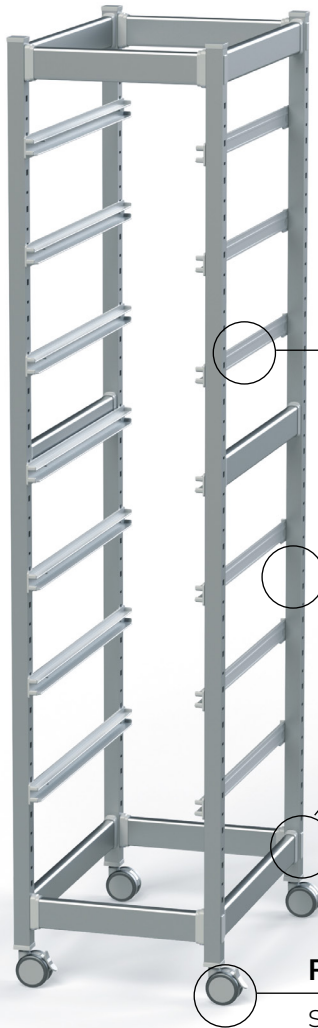

SCAFFALATURE MODULARI MODULAR SHELVING UNITS

Con infinite combinazioni è possibile modificare la configurazione in qualsiasi momento.

Thanks to the countless combinations, the design of the chosen solution can be changed at any time.

GUIDE - GUIDES

Resistenti e maneggevoli, si agganciano alla scaffalatura con estrema facilità.

Durable and easy to handle, can be easily attach.

SPALLA - SQUARE SECTION FRAME

Robusta e maneggevole, realizzata in lega leggera anodizzata. Disponibile in diverse altezze.

Sturdy and lightweight. Made light alloy, anodized after finish. Different heights available.

COPRI FORO - SQUARE FRAMES

Ulteriori distanziali possono essere aggiunti per modificare la configurazione della scaffalatura rimuovendo i copri fori, per procedere all'inserimento di una nuova spalla.

Additional spacers can be added to change the configuration of the shelving unit by removing the cover caps in order to proceed by adding extra square frames.

RUOTE - WHEELS

Si possono sostituire i piedini regolabili con le ruote di serie da Ø 65.

Standard adjustable feet can be replaced with Ø 65 mm wheels.



GUIDA TELESCOPICA TELESCOPIC GUIDE

Consente l'estrazione totale del ripiano/cesto; funzionale al facile posizionamento/prelievo di materiale.

Suitable for easy placement and retrieval of material from baskets and/or shelves.

SCAFFALATURA IN LEGA LEGGERA SHELVING IN LIGHT ALLOY

VANTAGGI SCAFFALATURA MOBILE - MOBILE SHELVING ADVANTAGES

La movimentazione manuale dei singoli moduli sulle basi di scorrimento permette di aprire un accesso per l'operatore alla corsia desiderata.

Ottimizzando così gli spazi inutilizzati, ne consegue un migliore utilizzo dello spazio destinato allo stoccaggio a favore di un incremento della capacità del magazzino

- Aumento delle capacità di stoccaggio almeno del **50%**
- Migliore organizzazione dello spazio
- Adatto a qualunque ambiente di lavoro

The movement of the each individual modules on the sliding base allows the operator to open an access to the desired aisle.

By optimizing unused areas, the result is better utilization of storage space in favor of increased storage capacity.

- Increase of storage capacity by **50%**
- Better organization of space
- Suitable for any work environment

Scaffalatura fissa
Fixed shelving

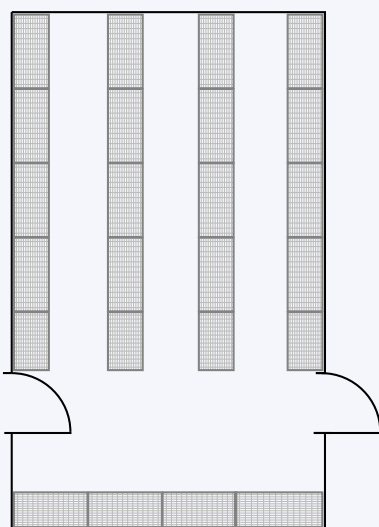

Scaffalatura mobile
Mobile shelving

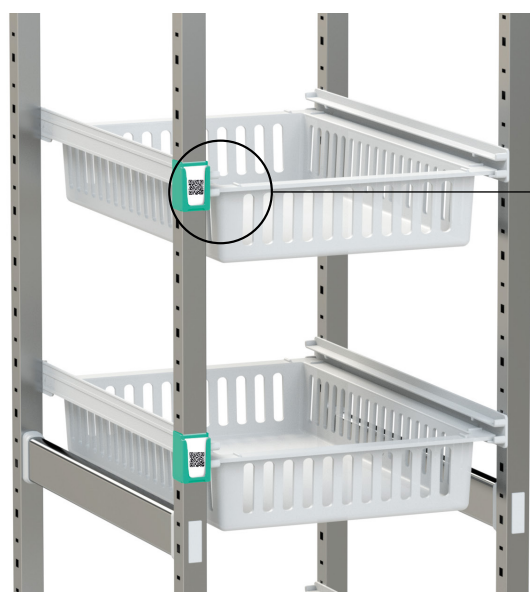
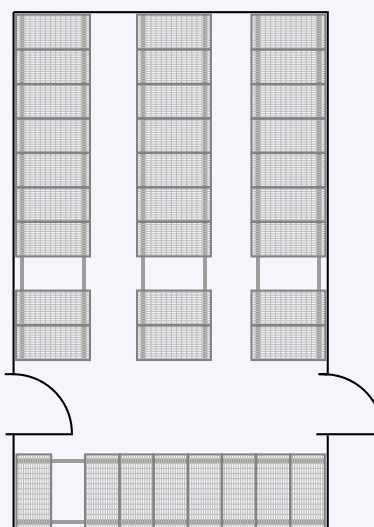

PORTA ETICHETTE LABEL HOLDERS

I nostri porta etichette, disponibili in diverse dimensioni, sono perfette per ordinare i vostri scaffali.

*Available in different sizes.
Suitable to organize storage.*



PANNELLI COLORATI IDENTIFICATIVI IDENTIFICATION COLORED PANELS



TOP-TRACK SYSTEM

Scaffalatura mobile con scorrimento superiore - *Mobile shelving with top sliding*

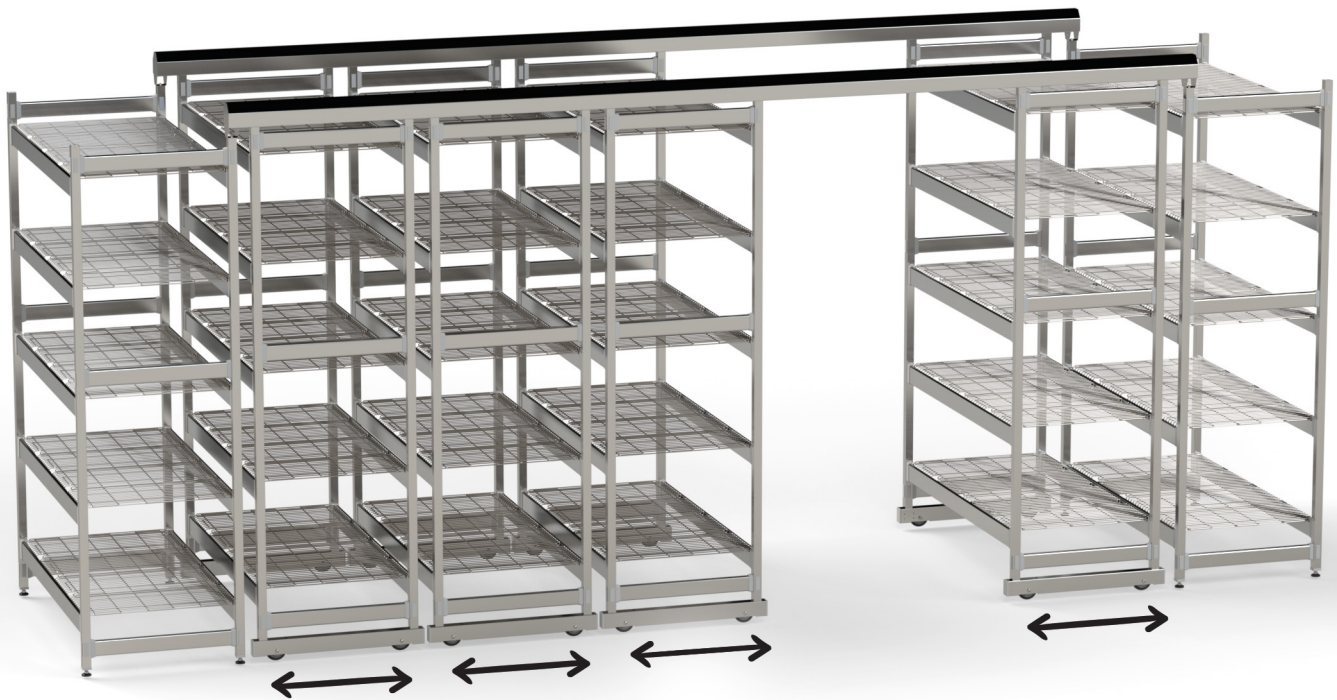

GROUND-TRACK SYSTEM

Scaffalatura mobile con scorrimento inferiore - *Mobile shelving with ground sliding*

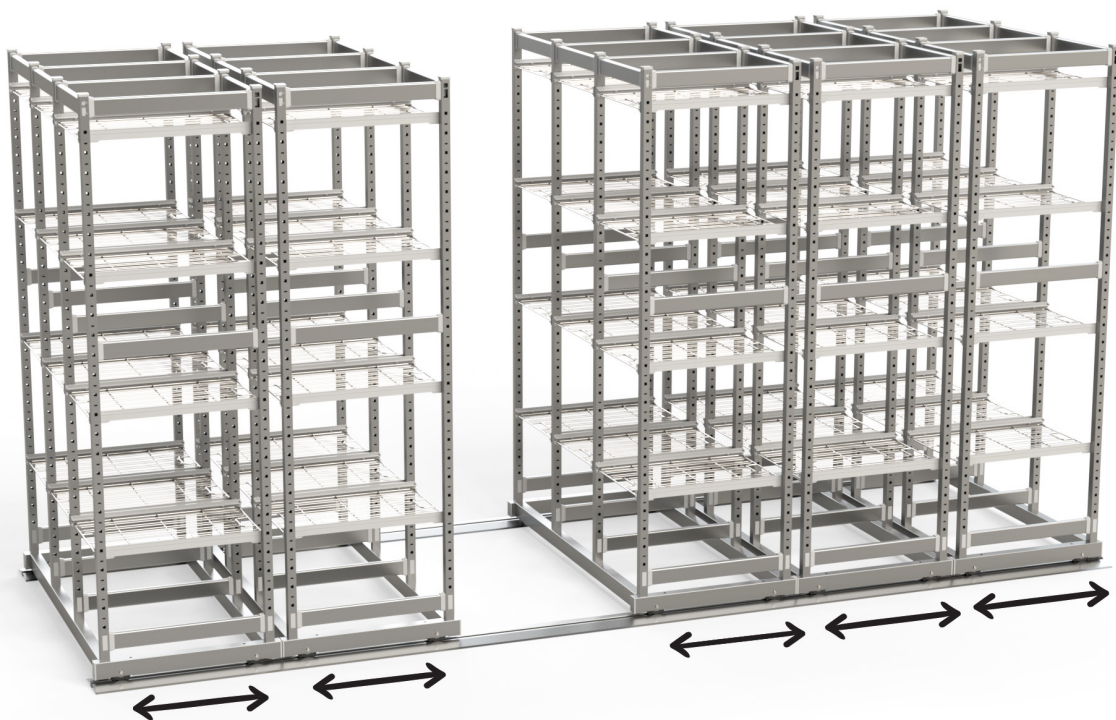

COMPONENTI SCAFFALATURA FISSA IN LEGA LEGGERA
 COMPONENTS FOR *FIXED SHELVING* IN LIGHT ALLOY

Spalla - Square section frame

LLUF

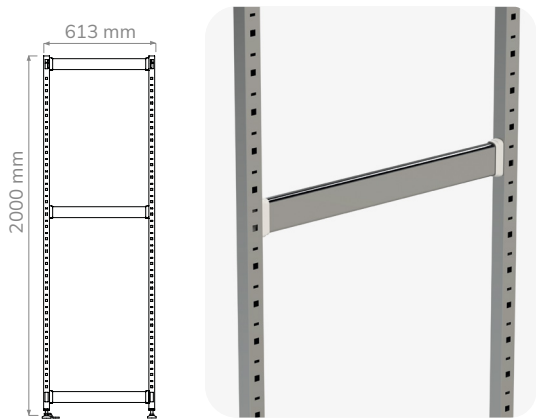

Distanziali - Spacer set

LLDIS (per guide - for guides)

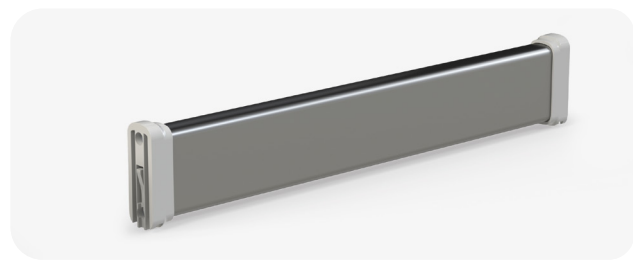
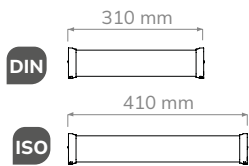

Piedino regolabile e ruote - Adjustable foot and wheels

LLUF-SP (standard)

LLUF-CR/RR (optional)



render demo:

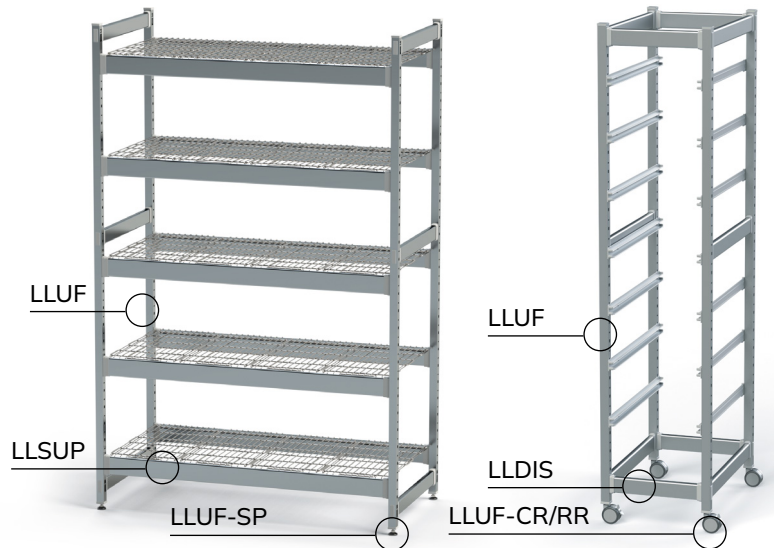

LLSUP (per ripiani - for shelves)

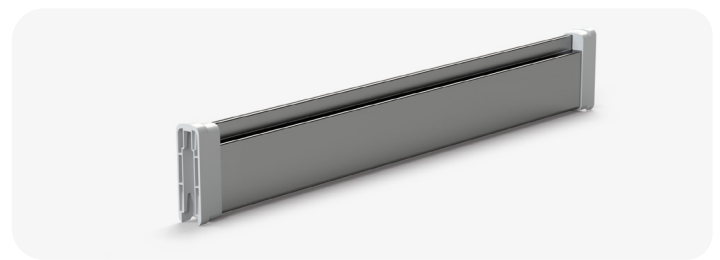
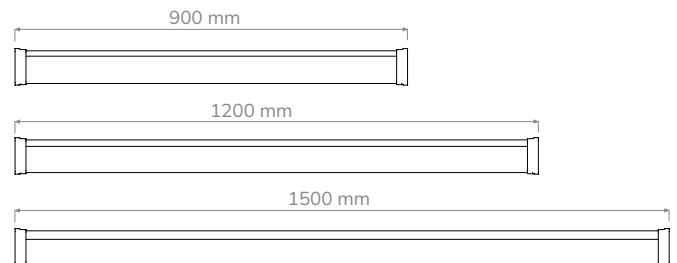

Sistema d'aggancio angolo
 Corner hooking system

LLANG



COMPONENTI **SCAFFALATURA MOBILE** IN LEGA LEGGERA
 COMPONENTS FOR **MOBILE SHELVING** IN LIGHT ALLOY

Elementi di scorrimento per TOP-TRACK system - *Sliding elements for TOP-TRACK system*

TPTK-REG



TPTK + TPTK-CAP



Elementi di scorrimento per GROUND-TRACK system - *Sliding elements for GROUND-TRACK system*

GRTK-REG



GRTK



Non ci sono limiti di lunghezza
 No lenght limit

Struttura per colonne - *Column square frame*

(GROUND-TRACK e TOP TRACK system)

SUPSP

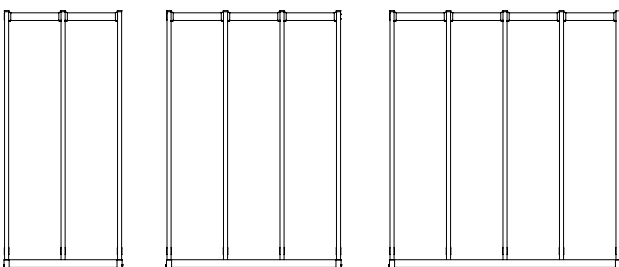

OPTIONAL SCAFFALATURE IN N LEGA LEGGERA OPTIONAL SHELVING IN LIGHT ALLOY

Guide - Guides

NY-RN60

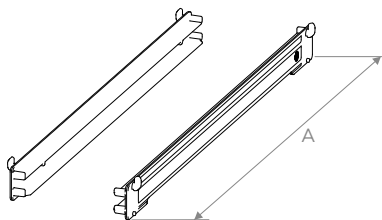

Coppia di guide in policarbonato.
Pair of polycarbonate guides.
Führungspaar aus Polycarbonat.
Paire de rails en polycarbonate.
Par de guías de policarbonato.

(mm)	A
NY-RN60	615

ISOTEL-RN



Struttura telescopica da agganciare alle guide NY-RN60 per ripiani e cesti.
Telescopic structure to attach on NY-RN60 guides. Suitable for easy access to shelf/basket content.
Teleskopstruktur zum Einhängen in NY-RN60 Führungen für Regale und Körbe.
Structure télescopique à accrocher aux glissières NY-RN60 pour étagères et paniers.
Estructura telescópica para enganchar a guías NY-RN60 para baldas y cestas.

Porta etichette- Label holders

LAB-HOL



Disponibili in diverse misure.
Different size available.
Erhältlich in verschiedenen Größen.
Disponible en différentes tailles.
Disponible en diferentes tamaños.

Pannelli identificativi - Identification panels



Disponibili in diversi colori (colori a richiesta).
Different colours available.
Verschiedene Farben verfügbar.
Différentes couleurs disponibles.
Diferentes colores disponibles.



RIPIANI e CESTI - SHELF and BASKET

UFWSH-AX (for LLSUP)

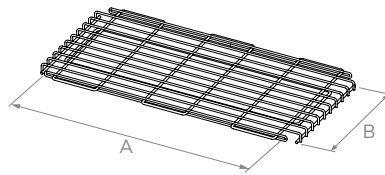
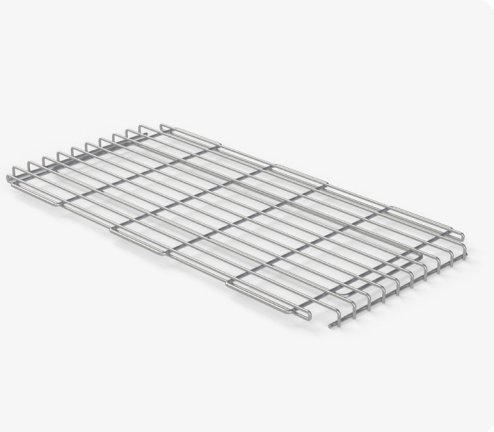

Ripiano in filo in acciaio inossidabile
 Stainless steel wire shelf.
 Regalboden aus Draht aus rostfreiem Edelstahl.
 Rayon en fil d'acier inoxydable.
 Estante en alambre de acero inoxidable.

(mm)	A	B
UFWSH-AX	600	300

UFWSH-AC (for LLSUP)

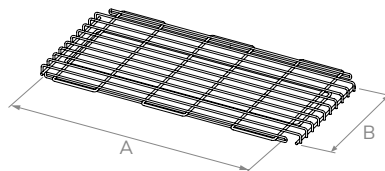
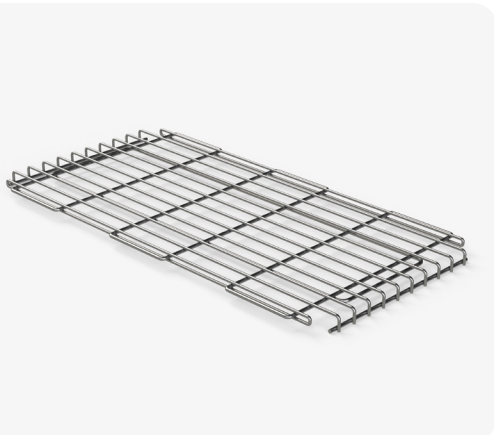

Ripiano in filo in acciaio cromato.
 Chromium steel wire shelf.
 Regal Boden aus Draht aus Chromstahl.
 Rayon en fil d'acier chromé.
 Estante en alambre de acero cromado.

(mm)	A	B
UFWSH-AC	600	300

SHELF (for NY-RN)

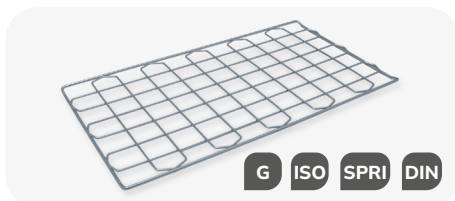

- * Ripiano in filo inox.
- * Stainless steel wire shelf.
- * Regalboden aus Draht aus rostfreiem Edelstahl.
- * Rayon en fil d'acier inoxydable.
- * Estante en alambre de acero inoxidable.

BAC6040



- * Contenitore ISO in policarbonato.
- * ISO polycarbonate container.
- * ISO-Behälter aus Polykarbonat.
- * Conteneur ISO en polycarbonate.
- * Contenedor ISO de policarbonato.

ISO6040 (for NY-RN)



- * Cesto in filo inox.
- * Stainless steel wire basket.
- * Korb aus Draht aus rostfreiem Edelstahl.
- * Panier en fil d'acier inoxydable.
- * Cesta de alambre de acero inoxidable.

* Vedi pagina 48/49 per le misure complete. * See page 48/49 for complete dimension chart.

Rev.01-10/2024

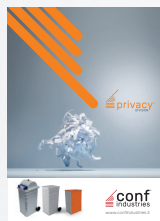
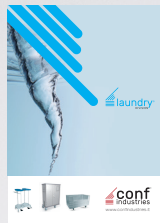

www.confindustries.com

Conf Industries S.r.l.
Via Casaglia 44/A
25039 Travagliato (BS) - Italy
Tel. +39 030 6863617
info@confindustries.it